

# Installation guide Ei6xxxGD...

- Eng Installation guide
- E Guía de instalación
- D Montageanleitung
- F Guide d'installation
- I Guida all'installazione

E i 650 m GD IM t h h r series  
E i 654 m GD IM t h h r  
E i 6P0 m GD IM t h h r

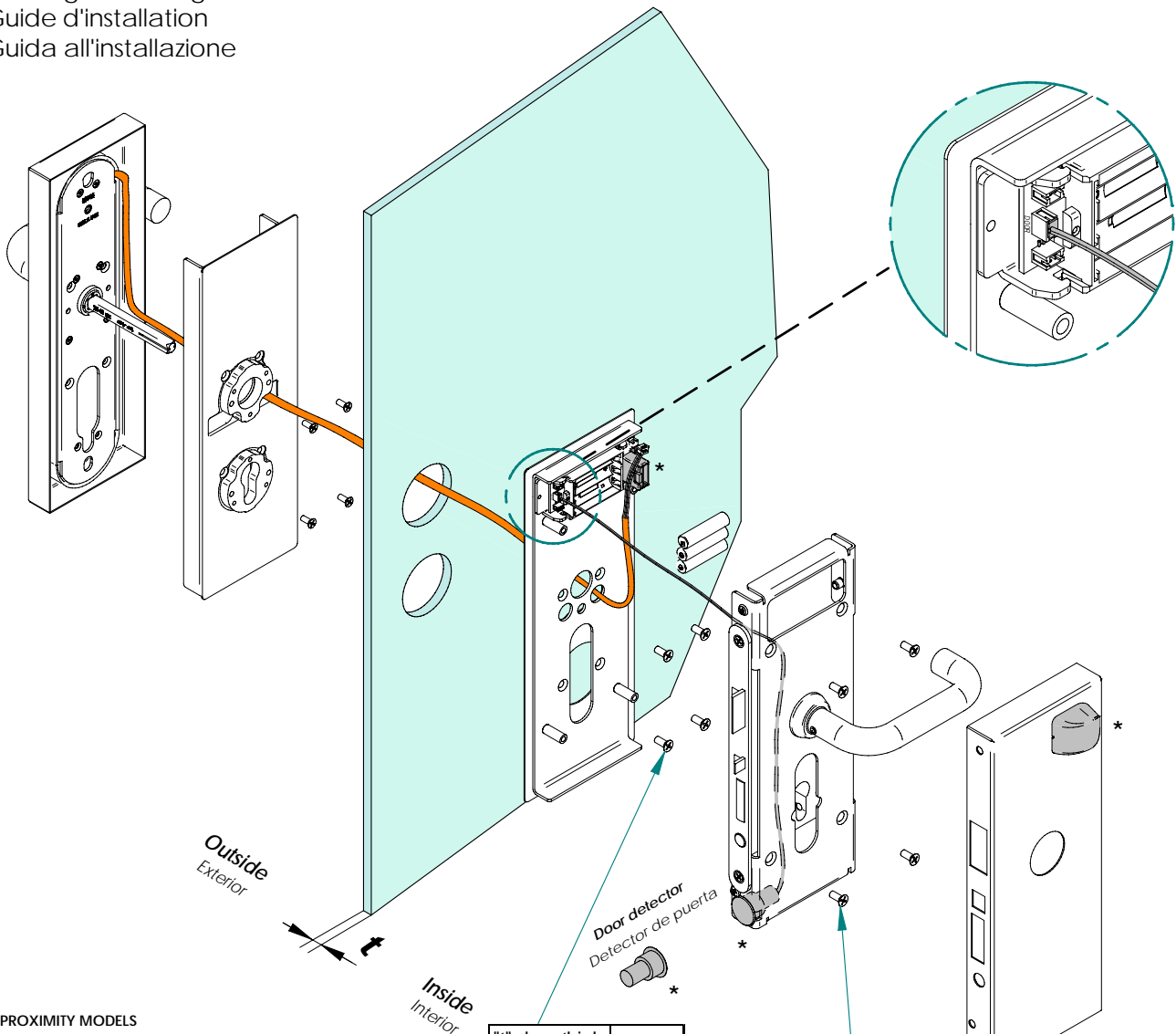

## ONLY FOR PROXIMITY MODELS

**Note:** This equipment has been tested and found to comply with the limits for a Class B digital device, pursuant to part 15 of the FCC Rules. These limits are designed to provide reasonable protection against harmful interference in a residential installation. This equipment generates, uses, and can radiate radio frequency energy and, if not installed and used in accordance with the instructions may cause harmful interference to radio communications. However, there is no guarantee that interference will not occur in a particular installation. If this equipment does cause harmful interference to radio or television reception, which can be determined by turning the equipment off and on, the user is encouraged to try to correct the interference by one or more of the following measures:

- Reorient or relocate the receiving antenna.
- Increase the separation between the equipment and receiver.
  - Connect the equipment into an outlet on a circuit different from that to which the receiver is connected.
  - Consult the dealer or an experienced radio/TV technician for help.

## Eng Declaration of conformity

By means of the present Salto Systems S.L. (Pol. Lanbarren C/Arkotz, 9 - 20180 Oiartzun - Spain - CIF B20708517), declares that this equipment fulfills the essential requirements and any other applicable or indispensable dispositions of the Directive 1999/5/CE or the Directive 89/336/EEC. You will be able to find a copy of the original declaration of conformity at the following Internet address:  
<http://www.saltosystems.com>

All proximity models are "Receiver class 3".

## E Declaración de conformidad

Por medio de la presente Salto Systems S.L. (Pol. Lanbarren C/Arkotz, 9 - 20180 Oiartzun - Spain - CIF B20708517), declara que este equipo cumple con los requisitos esenciales y cualesquiera otras disposiciones aplicables o exigibles de la Directiva 1999/5/CE o la Directiva 89/336/EEC. Podrá encontrar una copia de la declaración de conformidad original en la siguiente dirección de Internet:  
<http://www.saltosystems.com>

Todos los modelos de proximidad son "Receiver class 3".

**AT THIS POINT DO NOT CLOSE THE DOOR PROGRAM THE LOCK FIRST**  
follow user manual

**E** En este punto no cierre la puerta, programe primero la cerradura.  
Consulte el manual del usuario

Eng \* Only Wireless model

E \* Sólo modelo wireless

D \* Nur bei Wireless-Modellen

F \* Uniquement sur Wireless

I \* Solo modello wireless

Eng

**\*NOTE:**  
This device complies with part 15 of the FCC Rules. Operation is subject to the following two conditions: (1) This device may not cause harmful interference, and (2) this device must accept any interference received, including interference that may cause undesired operation.  
Note: This equipment has been tested and found to comply with the limits for a Class A digital device, pursuant to part 15 of the FCC Rules. These limits are designed to provide reasonable protection against harmful interference when the equipment is operated in a commercial environment. This equipment generates, uses, and can radiate radio frequency energy and, if not installed and used in accordance with the instruction manual, may cause harmful interference to radio communications. Operation of this equipment in a residential area is likely to cause harmful interference in which case the user will be required to correct the interference at his own expense.

E

**\*NOTA:**  
Este aparato cumple con la norma FCC apartado 15. Esta operación está sujeta a las siguientes dos condiciones: (1) El aparato no debe de producir interferencias perjudiciales, y (2) este aparato debe procesar cualquier interferencia recibida, incluidas interferencias que puedan causar funcionamiento no deseados.  
Nota: Este aparato ha sido testado y cumple con los requisitos para dispositivos digitales Clase A, conforme con la parte 15 de las normas FCC. Estos requisitos están establecidos para asegurar una protección razonable contra las interferencias perjudiciales cuando el dispositivo se utiliza en ámbitos comerciales. Este dispositivo, genera, utiliza, y puede producir energía de radiofrecuencia, y si no se instala y utiliza de acuerdo a las normas establecidas en sus manuales, puede producir interferencias negativas para la comunicación por radiofrecuencia. La utilización de este dispositivo en un entorno residencial puede generar interferencias negativas por lo cual el usuario debe, él mismo adecuar su uso correcto.

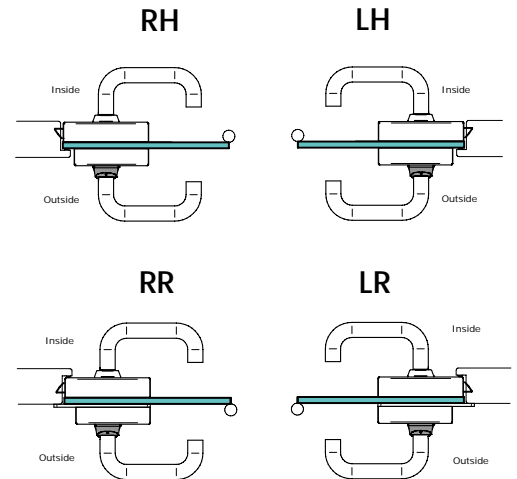
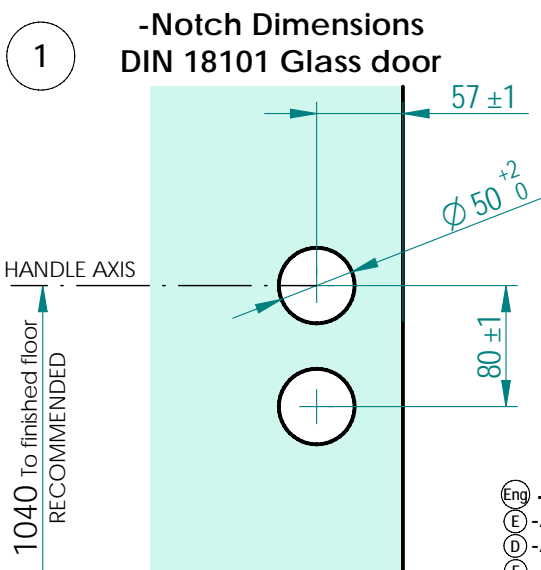

**Eng - Caution !**  
 E - Atención  
 D - Achtung  
 F - Attention  
 I - Attenzione

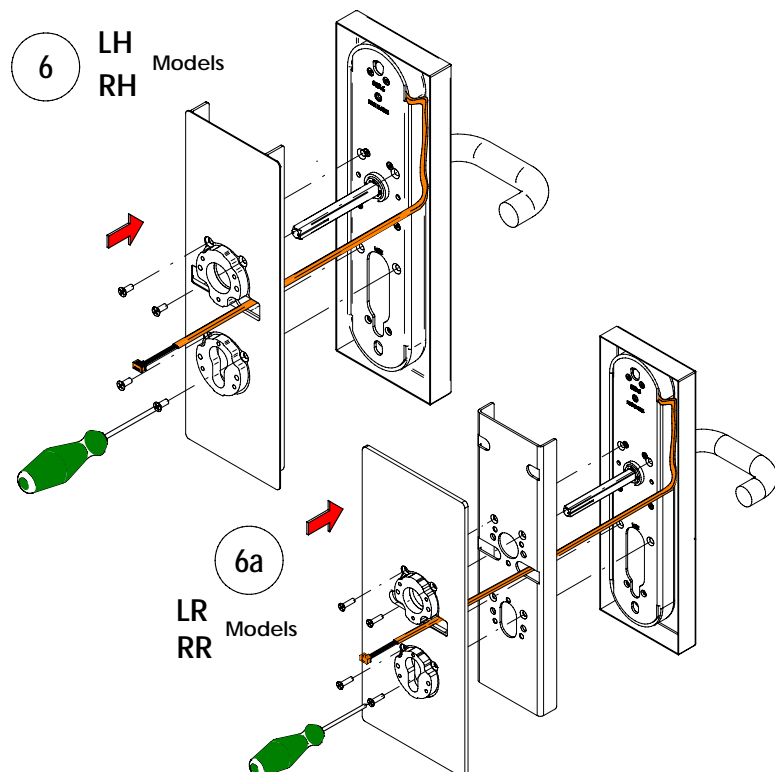
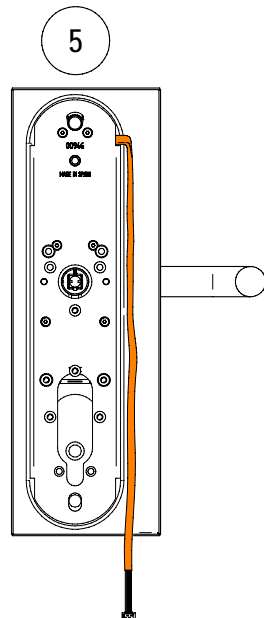
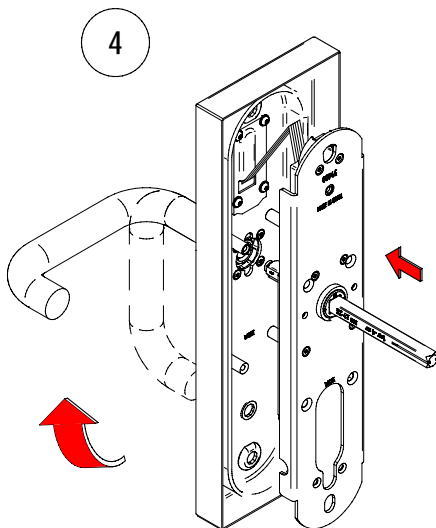
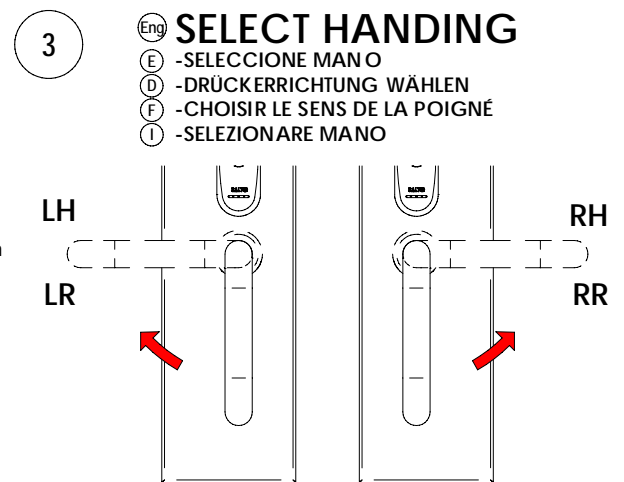
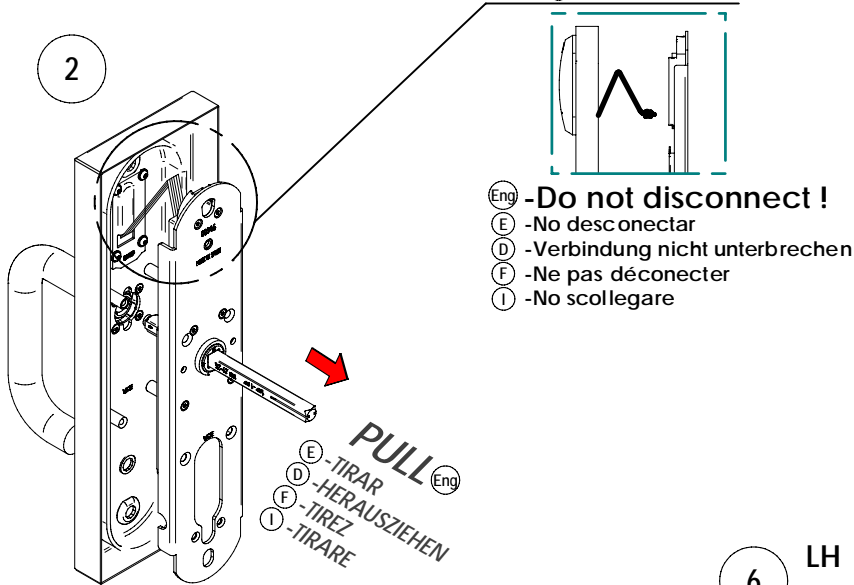

# Installation guide Ei6xxxGD...

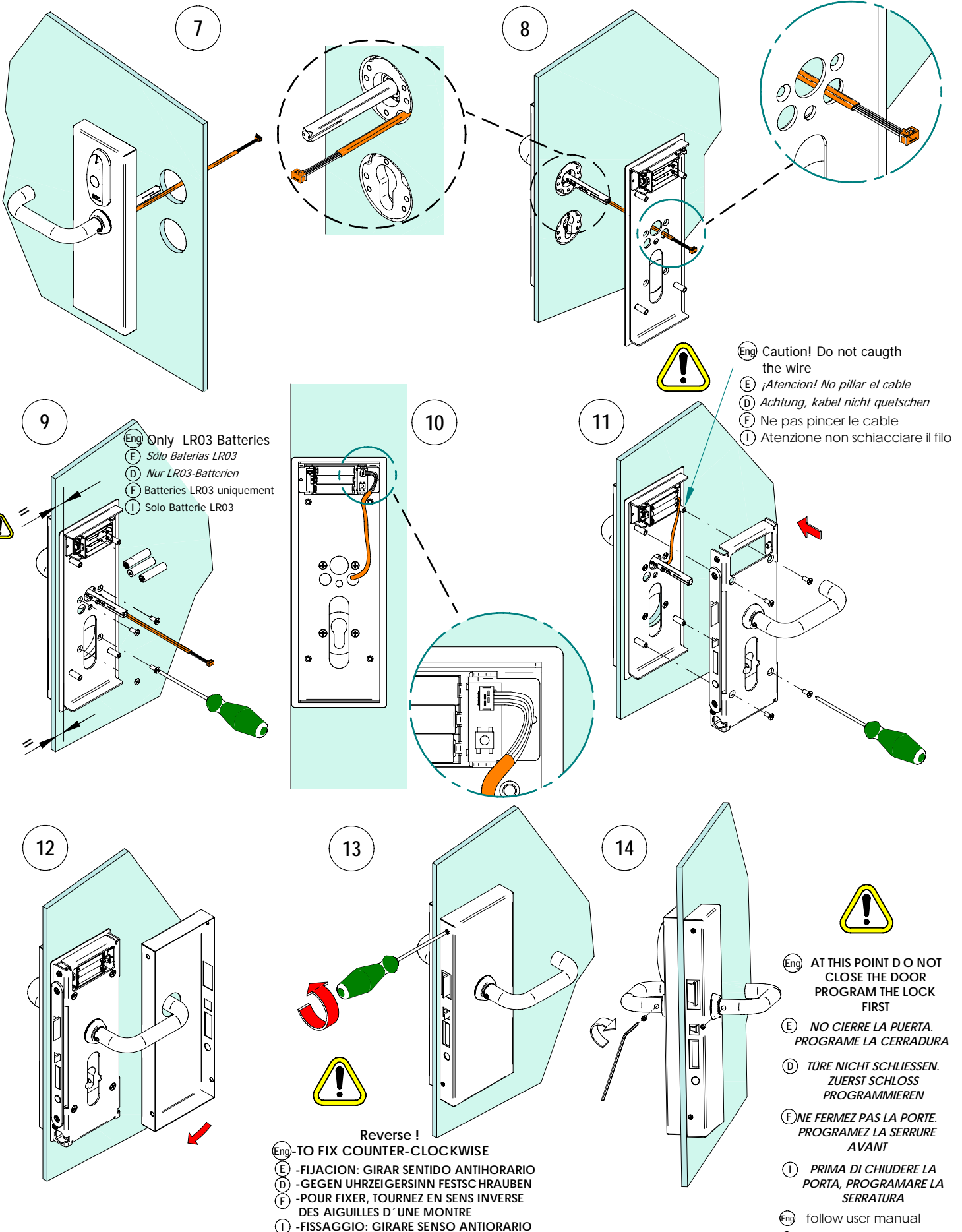

**Eng Strike plates for steel or wooden frames**

- Ⓔ *Cerraderos para marcos metálicos o de madera*
- Ⓓ Schliessbleche für Metall- oder Holzrahmen
- Ⓕ *Gâche pour encadrement métalliques ou en bois*
- Ⓘ Incontri per telaio in legno o in metallo

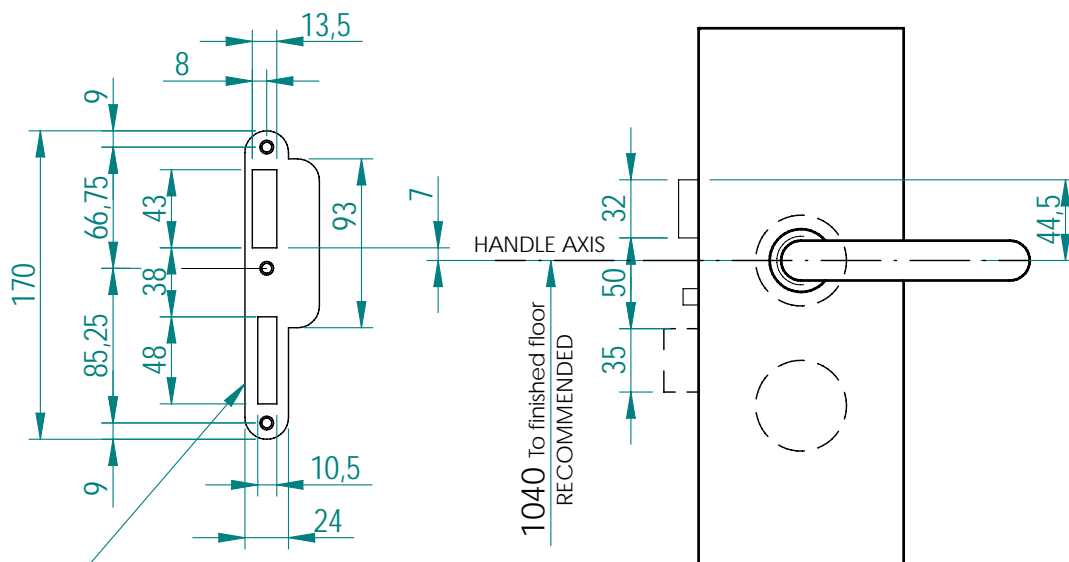
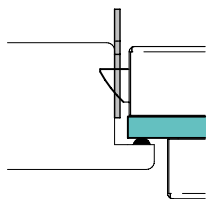
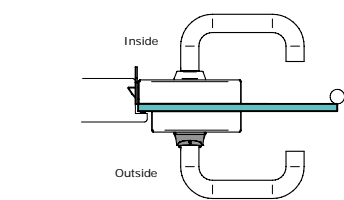

- Ⓔ Strike included
- Ⓔ *Cerradero incluido*
- Ⓓ Schliessblech inkludiert
- Ⓕ *Gâche incluse*
- Ⓘ Incontro incluso

**Eng Strike plates for Glass frames and fixed double doors**

- Ⓔ *Cerraderos para marcos de cristal y doble hoja fija*
- Ⓓ Gegenbeschläge für Glasrahmen und Standflügel von Doppelflügeltüren
- Ⓕ *Gâche pour encadrement en verre et double feuille fixe*
- Ⓘ Incontri per telaio in vetro e doppia anta fissa

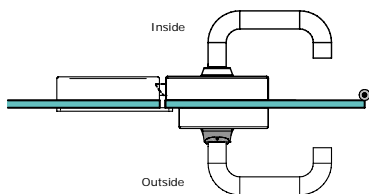

## CEGDxxIM

